

**CO₂ NEUTRAL
PRODUCTION**

ASSK
Automations-Systeme



Design freedom!
Fixed costs!
Universal application!



The cost-effective complete solution:
Angular Gripper WGR
including gripper jaws

ANGULAR GRIPPER WGR-PJ: PRINTED JAWS

**All good things come in three: Printed Jaws
...at a fixed price!**

For each size, a fixed price applies to our Angular Grippers including 3D-printed jaws: this is the WGR-PJ. Additionally the Angular Gripper WGR-PJ EP with EP-coated jaws is also available at a fixed price.

Perfectly matched gripping thanks to design freedom

The jaws are designed precisely to fit the parts you want to grip. All we need are the component data, and we will take care of the component-specific design within the specified installation space. The gripper jaws are designed as a negative of your component, while you define the gripping area.

For special gripping situations, tool requirements or clearance areas, we require design data from your side. Other dimensions or installation space analyses of course are available on request.

The 3D-printed jaws are made of a high-strength, durable Onyx material reinforced with continuous fibers. They cover all applications of conventional machined aluminum gripper jaws.

With the WGR-PJ EP, the gripper jaws are additionally coated with our EP-Coating to ensure a non-slip and gentle gripping.

Sustainable quality „Made-in-Germany“

The Angular Grippers WGR-PJ/EP are manufactured at our site in Overath near Cologne, along with the included gripper jaws, we offer sustainable and fast supply chains.

With the PRIMAKLIMA label "Climate protection contribution Scope 1, 2 & (3)," we have been offsetting our unavoidable emissions since 2019, thereby making a positive contribution to reducing your CO₂ footprint as well.

In addition, our quality management system has been certified to ISO 9001:2015 for several decades.

More in our online portal at <https://shop.ass-automation.com/> or go directly to the product group via the QR code:



PERFECTLY MATCHED TO YOUR COMPONENT: ANGULAR GRIPPER INCL. GRIPPER JAWS



Example:
WGR-PJ

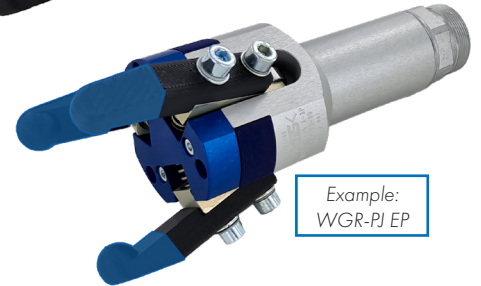

Example:
WGR-PJ EP

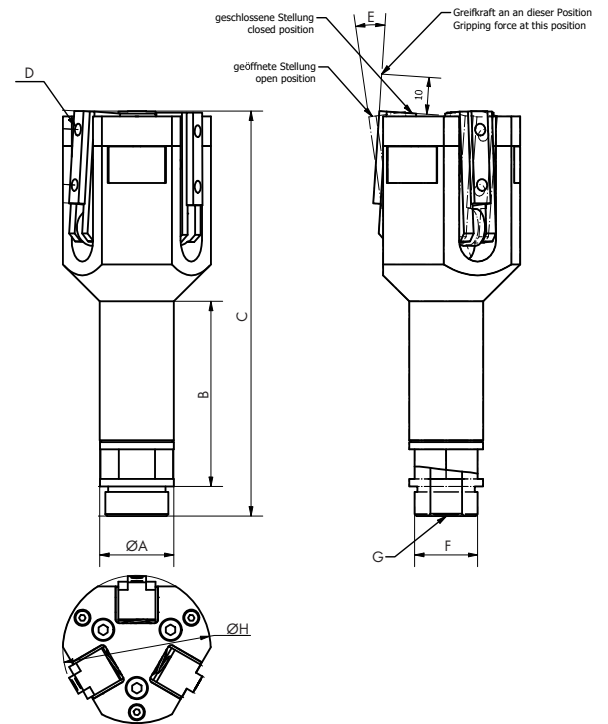

Part No.	Description	WGR-PJ	Gripping force* [N]
1-438-10-00	WGR-PJ 20-16 A-3P	Angular Gripper WGR with Printed Jaws	per jaw 110
1-438-13-00	WGR-PJ 30-25 A-3P	Angular Gripper WGR with Printed Jaws	per jaw 180

Part No.	Description	WGR-PJ EP	Gripping force* [N]
1-438-11-00	WGR-PJ EP 20-16 A-3P	Angular Gripper WGR with Printed Jaws + EP-Coating	per jaw 110
1-438-14-00	WGR-PJ EP 30-25 A-3P	Angular Gripper WGR with Printed Jaws + EP-Coating	per jaw 180

* The specified gripping force is measured with a jaw length of 10 mm and an operating pressure of 6 bar at the indicated position. The actual gripping force depends on the gripper jaw used. For further technical data, please refer to the standard Angular Gripper WGR without 3D-printed gripper jaws.