



**Grip centrally!**  
**Align precisely!**  
**Use universally!**

# Angular Gripper WGR

# ANGULAR GRIPPER WGR

## All good things come in three: Jaws

Our pneumatic Angular Grippers WGR with three jaws are particularly suitable for handling and positioning tasks involving round, rotationally symmetrical components. Their range of applications extends from machining and assembly stations to process automation for classic loading and unloading tasks. Thanks to the synchronous jaw movement, the Angular Grippers WGR ensure precise and reliable centering of the components.

Optional position feedback via a magnetic field sensor is available. A wide range of accessories and numerous connection options from our robotic hand modular system allow flexible applications for the user.

## Perfectly matched gripping

Thanks to individually customizable gripper jaws, the application areas of the Angular Grippers WGR are especially diverse.

Optionally, we design gripper jaws precisely matched to your workpiece. Depending on the application and material properties of the component, various materials are available:

- Machined aluminum gripper jaws
- 3D-printed gripper jaws made of high-strength Onyx material, reinforced with continuous fibers
- Additional EP-coating for particularly slip-resistant and extra gentle gripping

## Sustainable quality „Made-in-Germany“

The Angular Grippers WGR are manufactured at our site in Overath, near Cologne. Along with the optional gripper jaws, we offer you sustainable and fast supply chains.

With the PRIMAKLIMA label “Climate protection contribution Scope 1, 2 & (3),” we have been offsetting our unavoidable emissions since 2019, thereby making a positive contribution to reducing your CO<sub>2</sub> footprint as well.

In addition, our quality management system has been certified to ISO 9001:2015 for several decades.

More in our online portal at <https://shop.ass-automation.com/> or go directly to the product group via the QR code:

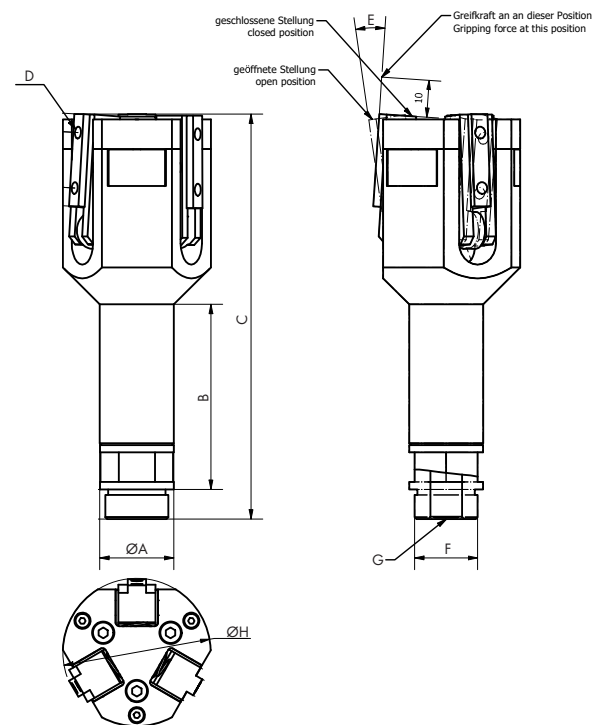

Part No.	Description	Ø A [mm]	B [mm]	C [mm]	D [mm]	E [°]	F [mm]
1-438-09-00	WGR 20-16 A-3P Angular Gripper, centering, 3-Jaw: Adapter	20	50	109	each jaw 2x M4	12	M17x1
1-438-12-00	WGR 30-25 A-3P Angular Gripper, centering, 3-Jaw: Adapter	30	58	123	each jaw 2x M5	21,2	M27x1

Part No.	Description	G [mm]	Ø H [mm]	Gripping force* [N]	Material	Weight [g]
1-438-09-00	WGR 20-16 A-3P Angular Gripper, centering, 3-Jaw: Adapter	G1/8	40	per jaw 110	Aluminium	153
1-438-12-00	WGR 30-25 A-3P Angular Gripper, centering, 3-Jaw: Adapter	G1/8	50	per jaw 180	Aluminium	284

\* The specified gripping force is measured with a jaw length of 10 mm and an operating pressure of 6 bar at the indicated position. The actual gripping force depends on the gripper jaw used.